



# DC PRO+

## 60-240kW



Estar DC Pro+ is mainly used for fast charging of electric vehicles. It is designed with self-developed control board, integrating the charging module, charging connector, human-machine interaction interface, communication, and other parts. The modular design of the Estar DC Pro+ makes it easy to install and simple to operate and maintain. It is an ideal choice for electric vehicles to charge in the public area.

# CONTENTS

---

1. Product appearance	3
2. Main function description	4
3. System working principle	5
3.1. System structure	5
3.2. Working principle	5
4. Product specification & parameter	6
4.1. Compliant standards	7
5. Models differences list	8
6. Installation instruction	9
6.1. Note	9
7. Security policy	10
8. Swipe card to start charging	12
9. Password to start charging	16
10. Scan the code to start charging	20
11. Indicator light status	23
12. Precautions for operation	24
13. Packaging, transportation and storage	24
14. Warranty and service	24

# PRODUCT APPEARANCE



## MAIN FUNCTION DESCRIPTION

---

- Without open door on back side, Estar DC Pro+ can be installed back to wall. Cover small area, easy to maintain.
- Internal charging module is designed with independent air space, isolated from the controlling part, to ensure the operating environment of controlling part clean and high stability.
- The system uses multi-module paralleled output mode, featured with flexible configuration and easy maintenance. Single module failure does not affect the system, greatly improving system reliability and stability.
- The charging module power can be intelligently allocated, high charging efficiency.
- With wide voltage output rang from 150V to 1000V, it is adjustable to meet the charging needs of different voltage levels of electric vehicles.
- All-round protections include input, output, components self-test and operation connection protection, input over/under voltage protection, DC output over voltage/short circuit protection, module overheating/fault protection, insulation protection, Estar DC Pro+ and battery connection inspection and other multiple protection functions, to ensure system operate safely and reliably and effectively prevent accidents.
- It supports four charging methods: card swiping, code scanning, plug and play, and password input.
- Human-machine interface adopts 10-inch color touchscreen with humanized design, easy and convenient to operate.
- The Estar DC Pro+ is designed to prevent rain and dust. IP55 protection grade meets the outdoor operation requirements.
- The function of charging plug falling off detection ensures the safety use during charging process.

# SYSTEM WORKING PRINCIPLE

## System Structure

The Estar DC Pro+ consists of 4 main parts. The first is human-machine interaction part. It includes the charging station body, touchscreen, RFID card reading module, charging plug. Secondly is the controlling part, which mainly refers the main monitoring and auxiliary module. The third part is the metering unit-electricity meter. The last part is safety protection unit, which is composed of lead-in line protection switch, emergency stop switch, over and under voltage protection unit, etc.

## Working Principle

When connecting the charging plug to the Estar DC Pro+, the controlling board will confirm the connection to wake up the charging module, which convert AC voltage into DC voltage for charging. Through the human-machine interface such as card reading module or touchscreen, the user give the charge/ disconnect/ query instructions. Then the Estar DC Pro+ will receive the instruction signals, communicate with the controlling board, and execute the instruction issued by the user. The main monitoring is not only responsible for many detections, like the detection of the charging port, the detection and control of the safety protection unit, the monitoring of the communication with the energy meter, to ensure the billing and user safety during charging process. It is also responsible for processing charging status, billing, alarm information, and then timely save the information and alarm fault in the controlling module.

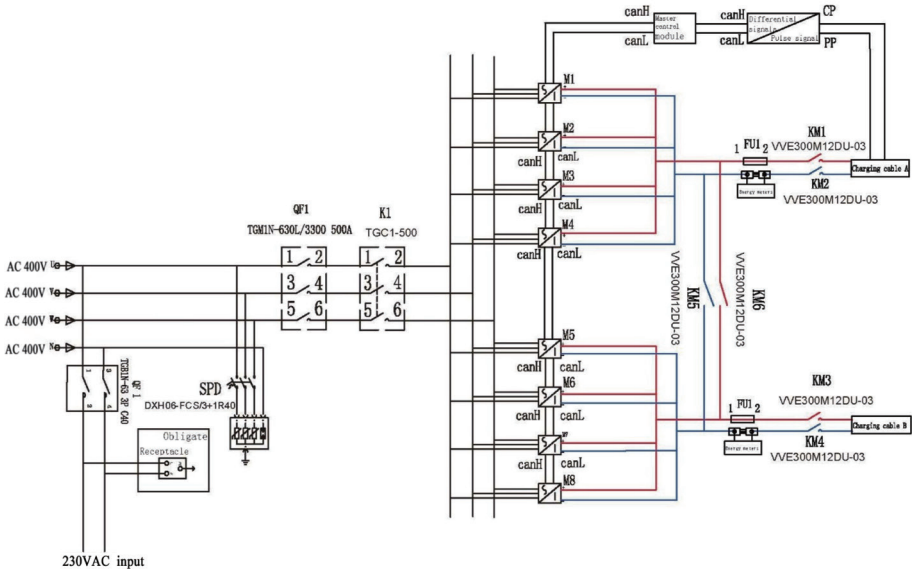

# PRODUCT SPECIFICATION & PARAMETER

Model	ES-DCP 60kW- CNX-001(S)	ES-DCP 90kW- CNX-001(S)	ES-DCP 120kW- CNX-001(S)	ES-DCP 150kW- CNX-001(S)	ES-DCP 180kW- CNX-001(S)	ES-DCP 240kW- CNX-001(S)
Output Power	60kW	90kW	120kW	150kW	180kW	240kW
Max. output current (single connector)	200A	250A				
Input Voltage	AC400V±20%, 3P+N+PE					
Input Frequency	50/60Hz					
Output Voltage	150-1000VDC					
Charging Connector	Dual Connectors with 5m charging cable (length customized available)					
Communication Interface	4G / LAN / WIFI ( Antenna need to be switched by hand when using from 4G to Wifi)					
Band information	Wi-Fi:2.4GHz RFID:13.56MHz GSM:B 3/8 LTE-FDD:B1//3/7/8/20					
Maximum data transfer rate	GSM:85.6 kbps(Download speed) / 85.6 kbps(Upload speed) TE-FDD:10 Mbps(Download speed) / 5 Mbps(Upload speed)					
Stable Voltage Accuracy	≤0.2%					
Stable Current Accuracy	≤0.2%					
High and low temperature steady current accuracy	≤0.2%					
Ripple Effective Value	≤0.2%					
Human Machine Interface	10-inch color touchscreen					
Efficiency	≥96%					
Power Factor	≥0.99					
Current Sharing Coefficient	≤5%					
Harmonic Current	≤4%					
Noise	≤65db					
Metering Accuracy	Level 1					
IP Grade	IP55					
Standby Power	≤Nx10W					
Cooling	Fan cooling					
Electrostatic discharge immunity	Class 4					
Surge immunity	Class 4					

# PRODUCT SPECIFICATION & PARAMETER

Model	ES-DCP 60kW- CNX-001(S)	ES-DCP 90kW- CNX-001(S)	ES-DCP 120kW- CNX-001(S)	ES-DCP 150kW- CNX-001(S)	ES-DCP 180kW- CNX-001(S)	ES-DCP 240kW- CNX-001(S)
Radio frequency electromagnetic field radiation immunity	Class 4					
Electrical fast transient burst immunity	Class 4					
Working Temperature	-20°C~+50°C					
Working Humidity	5%~95% no condensation					
Altitude	≤2000M					
Dimension WxDxH	970mm x 570mm x 1800mm					
Optional selection	POS payment					

## COMPLIANT STANDARDS

- IEC/EN 61851-1, IEC/EN 61851-2;NB/T 33001, NB/T 33008.1;EN 61000-3-2, EN 61000-3-3, EN 61000-6-2, EN 61000-6-4;
- IEC/EN 61851-21-2;IEC/EN 61851-24;
- DIN 70121, DIN 70122;
- GB/T 27930, GB/T 34658, GB/T 34657.1;
- EN301489-1, EN300220, EN301908;

## MODELS DIFFERENCES LIST

Model	Input	Output	Gross Weight
ES-DCP60kW -CNX-001	AC400V±20%, 91A	CCS2:150-1000V,single connector 200A Max,60kW	Mass. 260kgs
ES-DCP60kW -CNX-001S	AC400V±20%, 91A	CCS2:150-1000V,single connector 200A Max,60kW, Equipped with a cable management system	Mass. 267kgs
ES-DCP90kW -CNX-001	AC400V±20%, 136A	CCS2:150-1000V,single connector 250A Max,90kW	Mass. 281kgs
ES-DCP90kW -CNX-001S	AC400V±20%, 136A	CCS2:150-1000V,single connector 250A Max,90kW, Equipped with a cable management system	Mass. 288kgs
ES-DCP120kW -CNX-001	AC400V±20%, 182A	CCS2:150-1000V,single connector 250A Max,120kW	Mass. 297kgs
ES-DCP120kW -CNX-001S	AC400V±20%, 182A	CCS2:150-1000V,single connector 250A Max,120kW, Equipped with a cable management system	Mass. 304kgs
ES-DCP150kW -CNX-001	AC400V±20%, 228A	CCS2:150-1000V,single connector 250A Max,150kW	Mass. 314kgs
ES-DCP150kW -CNX-001S	AC400V±20%, 228A	CCS2:150-1000V,single connector 250A Max,150kW, Equipped with a cable management system	Mass. 321kgs
ES-DCP180kW -CNX-001	AC400V±20%, 273A	CCS2:150-1000V,single connector 250A Max,180kW	Mass. 330kgs
ES-DCP180kW -CNX-001S	AC400V±20%, 273A	CCS2:150-1000V,single connector 250A Max,180kW, Equipped with a cable management system	Mass. 337kgs
ES-DCP240kW -CNX-001	AC400V±20%, 365A	CCS2:150-1000V,single connector 250A Max,240kW	Mass. 364kgs
ES-DCP240kW -CNX-001S	AC400V±20%, 365A	CCS2:150-1000V,single connector 250A Max,240kW, Equipped with a cable management system	Mass. 371kgs

# INSTALLATION INSTRUCTION

Estar DC Pro+ foundation size construction (attention to keep one hole in the middle of the cement foundation for cables)

Generally, the integrated Estar DC Pro+ is installed on the concrete ground. Please refer to the following figure:

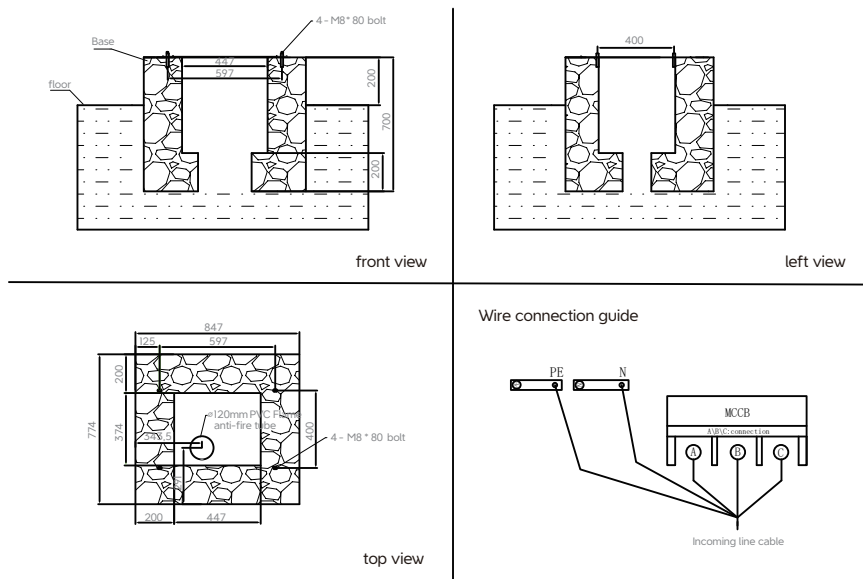

## NOTE:

1. This model are 60-240kw Estar DC Pro+ and the concrete stage should be set up at the installation location of the car charger. As is shown in the above figure, the concrete grade not lower than C20:
2. The concrete stage should ensure a complete appearance, flatness, and no cracks. The embedded pipelines should match the hole position of the charging pile bottom plate to avoid inconsistency between the pipeline and hole position.
3. When wiring connection of Estar DC Pro+, the cable should follow the protective tube to the circuit breaker inside the chassis. This model uses three-phase electricity A (yellow), B (green), and C (red) three-phase are correctly connected to the circuit breaker according to the national standard color code, N line (light blue) is connected to the busbar, and PE line (yellow green alternating) is connected to the PE busbar. The cable end at the overlap should use DT to ensure stability and reliability. Before power on, pls check and make sure that there is no short circuit in the input circuit.

## **Overvoltage and undervoltage protection on the AC input side**

When the AC input overvoltage or undervoltage occurs, the Estar DC Pro+ will automatically cut off the DC output and send alarming.

## **Overvoltage protection on the DC output side**

When the DC output overvoltage occurs, the Estar DC Pro+ will automatically cut off the DC output and send alarming signal.

## **Overcurrent protection on the DC output side**

When overcurrent occurs on the DC output side, the Estar DC Pro+ will automatically cut off the DC output and send alarming signal.

## **Short-circuit protection on the DC output side**

When the DC output occurs short-circuit, the Estar DC Pro+ will automatically enter the current limiting output state.

## **Lightening surge protection**

The Estar DC Pro+ is equipped with a C-class lightning protection device, which has the function of lightning surge protection. It can effectively prevent direct lightning, inductive lightning or overvoltage from damage to the charging equipment.

## **Battery current backflow protection**

The Estar DC Pro+ has the function of preventing battery current backflow from causing harm to charging equipment and personal safety.

## **Over-temperature protection**

When the AC-DC conversion power unit overheats, the Estar DC Pro+ will automatically cut off the DC output and send alarming signal.

## **Power battery abnormal detection**

When establishing the connection between the Estar DC Pro+ and BMS, the DC output circuit of the Estar DC Pro+ is not allowed to connect to the battery until the power battery polarity is correctly detected. During the charging process, when the temperature and voltage of the power battery exceed the limit value, the Estar DC Pro+ will automatically stop charging.

## **Power battery connecting confirmation**

The charging process will start only when the Estar DC Pro+ is correctly connected to the EV's battery system. If abnormal connection detected, it will automatically cut off the DC output immediately.

# SECURITY POLICY

---

## **Temperature monitoring and alarm**

The built-in temperature monitoring device in the charging connector monitors the temperature rise of the main power conduction pin in real time. If exceeds the setting value, the system will alarm and cut off the DC output to prevent the Estar DC Pro+ and vehicle damage and personal injury.

## **Emergency stop**

Equipped with the emergency stop on the DC charging station, the personnel can cut off the charging circuit within 100S on the hardware under the emergency cases. It helps to prevent many vicious events such as electric shock, fire, or explosion, etc.

# SWIPE CARD TO START CHARGING

By swiping online or offline card, Estar DC Pro+ can realize the functions of start, stop charging, refund and so on.

Main charging steps are as follows:

**Step 1:** Select an idle charging station, insert the connector correctly into the charging vehicle, and click the touch screen to select the charging connector.



As shown in the following figure, select any login method.



# SWIPE CARD TO START CHARGING

**Step 2:** Choose any charging method as shown in the following figure.



**Step 3:** Click to confirm charging and enter the system self-test, waiting for charging to start.

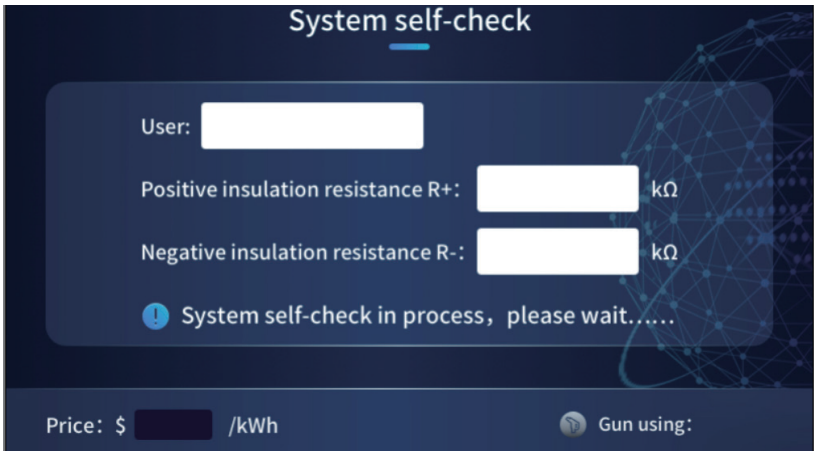

# SWIPE CARD TO START CHARGING

Normal charging interface (taking card swiping charging as an example)



**Step 4:** To end the order in advance, you need to swipe your card, complete the charging process, and the amount settlement interface will appear (taking swipe card charging as an example).



## SWIPE CARD TO START CHARGING

---

Pay the consumption amount by swiping the card again and refund the remaining withholding fee.

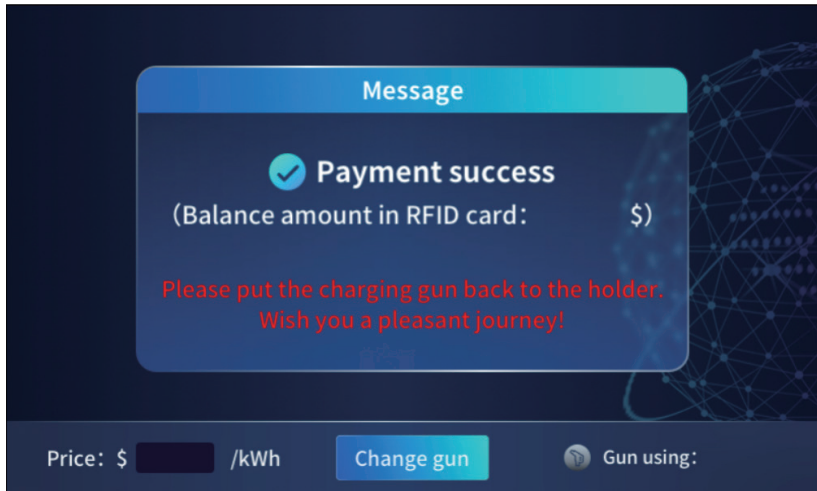

## PASSWORD TO START CHARGING

Password activated charging stations can be started and stopped using a password. The main steps of charging are as follows:

**Step 1:** Select an idle charging station, insert the connector correctly into the charging vehicle, and click the touch screen to select the charging connector.



**Step 2:** After clicking on the interface, as shown in the figure below, select the password charging method.



# PASSWORD TO START CHARGING

---

After selecting the password charging method, enter the password.

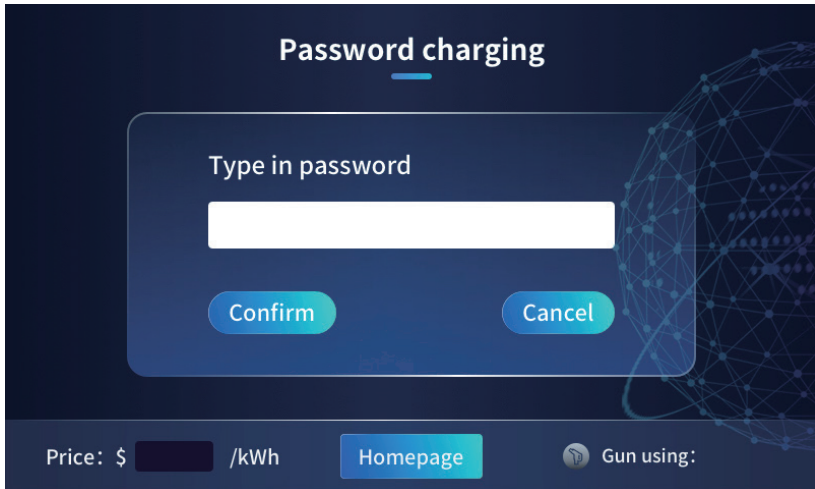

# PASSWORD TO START CHARGING

**Step 3:** After confirming the password and charging, enter the system self-test and wait for the charging to start.

## Insulation testing

Positive leakage current:  mA

Negative leakage current:  mA

Busbar voltage:  V

Positive insulation resistance:  kΩ

Negative insulation resistance:  kΩ

Status reminding:



Normal charging interface

## In charging

User:

Type in password to stop charging

%

- Charging voltage: V
- Charging current: A
- Charging electricity: kWh
- Charging time: MIN.
- Consumption amount: \$

 Stop charging process by password!

Price: \$  /kWh   Gun using:

## PASSWORD TO START CHARGING

---

**Step 4:** Ending the order early requires entering the password again, charging is completed, and the settlement interface appears.

Charging ended, please pull out the gun

User:

Electricity charged:  kWh

Charging time:  MIN.

Consumption amount:  \$

SOC:  %

Ended charging reason:

Price: \$  /kWh [Change gun](#) Gun using:

# SCAN THE CODE TO START CHARGING

The charger can be started and stopped by scanning the code with a mobile phone. The main steps of charging are as follows:

**Step 1:** Select an idle charging station, insert the connector correctly into the charging vehicle, and click the touch screen to select the charging connector.



**Step 2:** After clicking on the interface, as shown in the figure below, select the scan code charging method.



# SCAN THE CODE TO START CHARGING

After selecting the QR code charging method, scan the QR code that appears on the screen.

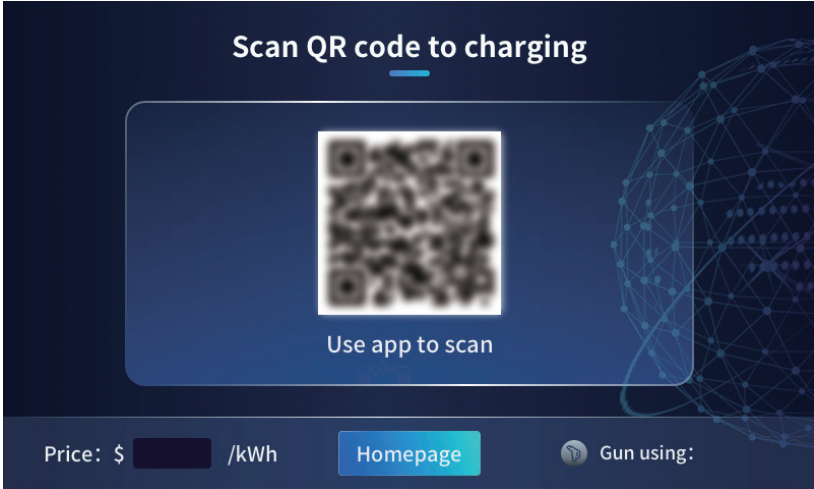

**Step 3:** After scanning the code to charge, enter the system self-test and wait for the charging to start.

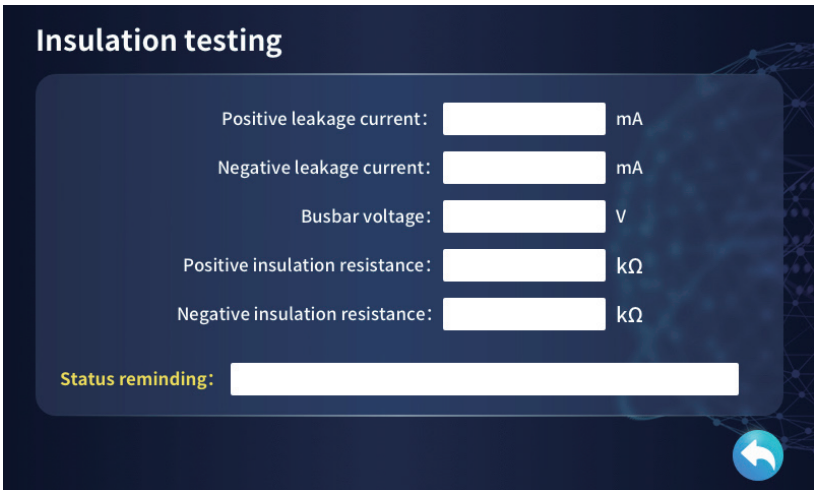

# SCAN THE CODE TO START CHARGING

Normal charging interface

**In charging**

User:

Type in password to stop charging

SOC %

- Charging voltage: V
- Charging current: A
- Charging electricity: kWh
- Charging time: MIN.
- Consumption amount: \$

! Stop charging process by password!

Price: \$  /kWh

**Step 4:** Ending the order in advance requires confirmation from the mobile phone that the charging has been completed, and a settlement interface will appear after the charging is finished.

**Charging ended, please swipe RFID card to pay the bill**

User:

Electricity charged:  kWh

Charging time:  MIN.

Consumption amount:  \$

Balance amount in RFID card:  \$ SOC:  %

Ended charging reason:

Price: \$  /kWh

# INDICATOR LIGHT STATUS

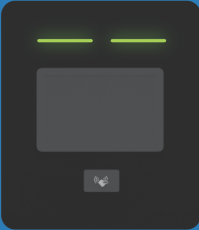
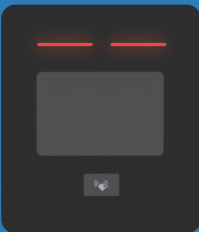
Status	Describe	Status description
	<p>The blue light is constantly on</p>	<p>Standby</p>
	<p>The green light is constantly on</p>	<p>Charging</p>
	<p>The red light is constantly on</p>	<ol style="list-style-type: none"> <li>1. When the emergency stop button is pressed, the indicator light is red and constantly on</li> <li>2. When charging, the door is opened, the indicator light is red and constantly on</li> </ol>

## PRECAUTIONS FOR OPERATION

---

- Due to some vehicle models cannot be charged after locking the car for a few hours, please plug in the connector and charge it promptly after locking the car.
- During the charging process, the user shall not directly pull out the charging connector by force.
- The Estar DC Pro+ should be used under the environmental conditions specified in this specification.
- If need to stop charging in advance, please follow the specifications. Stop charging first and then pull out the connector.
- If safety accident happens during the charging process, such as abnormal sound, short circuit and other emergencies, press immediately the emergency stop button, disconnect the power, and then notify the site management personnel or call the manufacturer for maintenance.

## PACKAGING, TRANSPORTATION AND STORAGE

---

- The Estar DC Pro+ is packed in a ultrahard material carton. Pls keep sure that there is no severe vibration, impact, tumbling or inversion during transportation.
- The Estar DC Pro+ should be stored in a dry and ventilated environment. And it is strictly prohibited to stack them in the open air. They should be placed in a warehouse without corrosive and explosive gases.
- All texts and illustrations correspond to the technical status at the time of writing. Estar reserves the right to make unannounced changes. The content of the operating instructions does not justify any claims against the manufacturer. Pictures are for illustration purposes and may differ from the actual product.

## WARRANTY AND SERVICE

---

### After Service

Please refer to the contract for the warranty period. The specific after-sale plan will be free for replacement or charging a certain maintenance cost according to the specific situations. During the warranty period, customers can apply for replacement or free maintenance for the fault damage caused by product quality.

For the fault damage caused by other reasons(human factors, natural factors, etc.), we will provide paid maintenance services.

